

Miniature Variable Optical Delay Line (VDL-004)



The VDL-004 is a miniature variable optical delay line designed specifically for OEM applications. This device offers continuous control with high precision, zero backlash, and good thermal stability. An internal mirror can be installed to cause light to double pass the device, doubling the delay range. A locking mechanism is provided for locking the delay at a permanent position. The VDL-004 generally comes with single mode or PM fiber pigtailed per customer requirement. With a footprint of only 78×22×15 mm for a delay range of 130 ps (40 mm), the device can be easily integrated into larger instruments or assemblies for precision optical path length control or timing alignment. Convenient mounting brackets allow mounting in any orientation, as well as easy integration of multiple units on a base plate to form an array.

Specifications:

Operating Wavelength ²	SM: 840 ± 50nm, 1060 ±50 nm, 1260-1650 nm PM: 840, 1060, 1310 or 1550 nm ± 50 nm
Optical Delay Range ¹	0 ~ 130 ps (40mm) continuous
Optical Delay Resolution ¹	Continuous 3.34 ps (1 mm) per full turn
Delay Temperature Stability ¹	(0.52+0.008*delay) μm/°C where "delay" = optical delay in mm
Delay Repeatability ^{1,3}	<20μm
Zero Point Delay Offset ^{1,4}	230 ps
Insertion Loss ¹	<0.8 dB
Insertion Loss Variation ¹	<0.4 dB over entire range
PDL ¹	0.1 dB for single mode fiber
Return Loss ¹	55 dB
Extinction Ratio	>20 dB for PM model
Optical Damage Power Threshold	300 mW
Operating Temperature	-15°C to 55°C
Storage Temperature	-40°C to 80°C
Fiber Type	840nm: HI780 or PM Panda 1060nm: HI1060 or PM Panda 1310 and/or 1550nm: SMF-28 or PM Panda
Position locking	Included
Dimensions	78 (L) × 22 (W) × 15 (H) mm
Notes:	<ol style="list-style-type: none"> Specifications in table apply for a single-pass device without connectors, measured over 1310 ± 50 nm or 1550 ± 50 nm at 23±5°C. The output pigtail can also be replaced with a Faraday mirror to create a double pass device with a total range of 260 ps. Specifications may be different for double pass devices or for wavelengths other than 1310 or 1550nm. Other wavelengths available upon request. Contact General Photonics for details. Optical delay variation after rotating the dial 2 full turns in one direction, then returning to original position. Absolute delay at 0ps setting, excluding fiber.

Features:

- Compact
- Continuous Adjustment
- Zero Backlash
- Low Insertion Loss
- High Stability
- Durable
- Flexible mounting options

Applications:

- Microwave Photonics
- Phased Array Antennas
- Coherent Detection Systems
- Optical Time Division Multiplexing (OTDM)
- Optical Coherence Tomography (OCT)
- Optical Interferometry
- Optical Fourier Spectrum Analysis
- Fiber Sensors

Related Products:

- Motorized Delay Lines ([MDL-002](#), [MDL-003](#))
- Manual Delay Line ([VDL-002](#), [VDL-001](#))
- [Components](#)

Tech Info:

- [Optical Coherence Tomography Technologies](#)

FAQ:

- [Delay Lines](#)

Miniature Variable Optical Delay Line (VDL-004)

Dimensions (in mm):

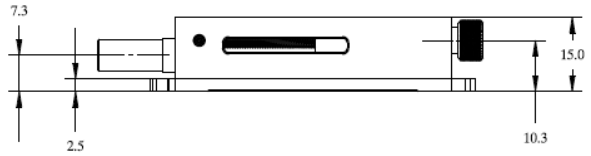
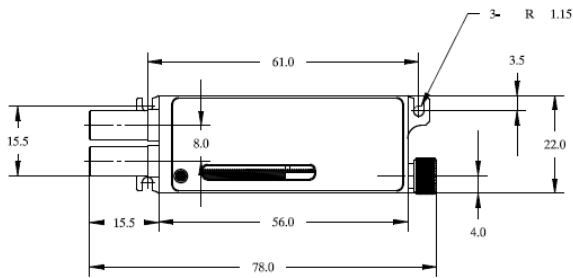

Base Plate:

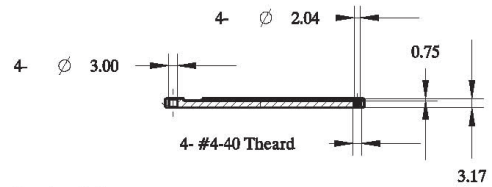
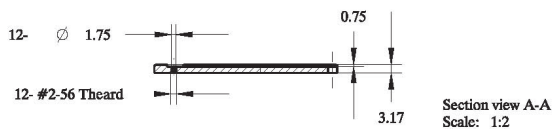
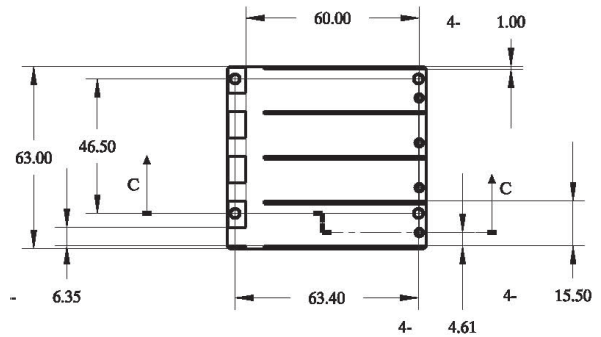
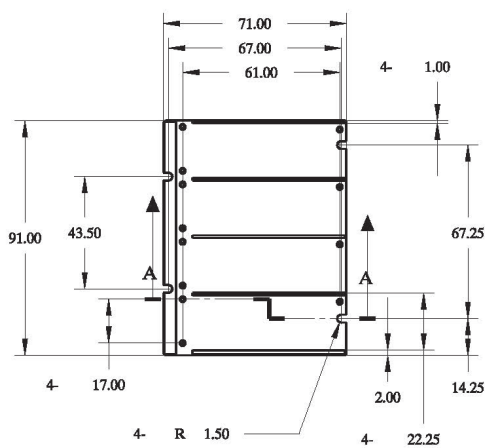

For horizontal fix

For vertical fix

Array Mounting Options:

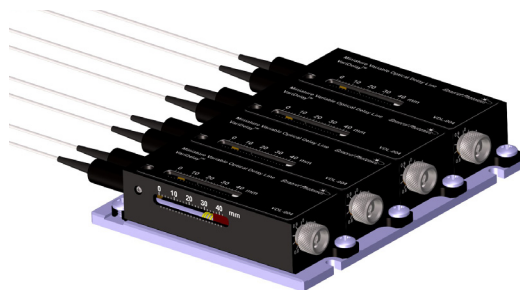

Horizontal mounting



Vertical mounting

Miniature Variable Optical Delay Line (VDL-004)

Typical Performance Data:

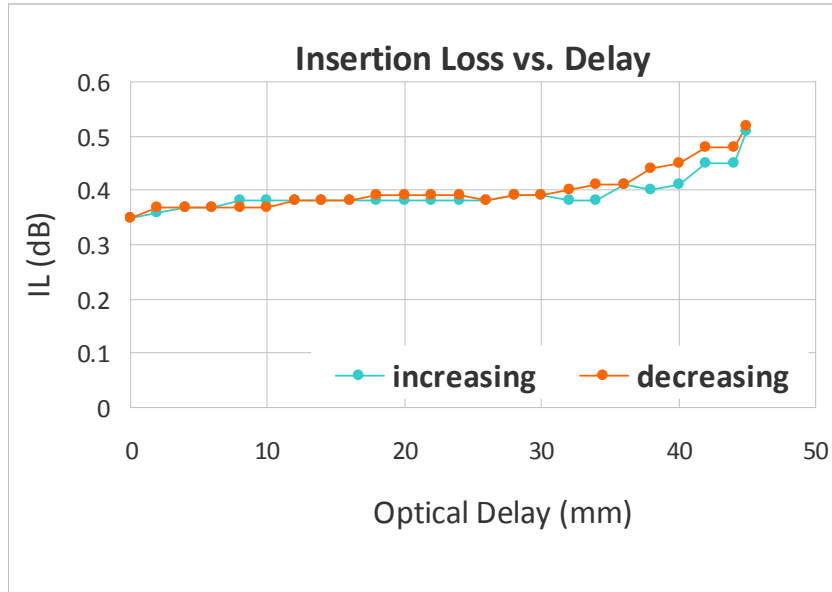

Insertion loss vs. position measured while increasing or decreasing delay setting. The IL variation is low over the measured range, and the IL at any given position is independent of the direction of motion.

Ordering Information:

Delay Line:



- Configuration Notes:**
1. Wavelength: 35 option (dual window 1310/1550nm) is available only for SM single-pass devices. PM or double-pass devices are single-window (e.g. 1310 or 1550nm) only.
 2. Double-pass only available with SM fiber.
 3. Double-pass not available for 840 or 1060nm.

Wavelength:
 84 = 840 nm
 10 = 1060 nm
 13 = 1310 nm (PM)
 15 = 1550 nm (PM)
 35 = 1310/1550 (SM)

Delay Range:
 13 = 130ps

Pass:
 S = single
 D = double

Fiber Type:
 SS = SM to SM
 PP = PM to PM

Connector Type:
 FC/PC, FC/APC
 SC/PC, SC/APC or
 NC = No Connectors

Base Plate:

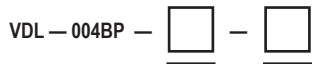

Orientation:
 H = Horizontal
 V = Vertical

VDLs that can be mounted:
 4