

Online Sensor Solution CID1

T-Gauge® SCS500n



The T-Gauge Explosion Proof Thickness Measurement System (SCS500n) takes the robustness of the T-Ray® 5000 to a new level with the ability to operate in flammable atmospheres, such as paint booths or coating facilities. The sensor is designed to be robot mountable and intrinsically safe. The SCS500n is optimized for use in spray booth applications, but can be used in other applications as well. The working distance of the sensor head is fixed at 115 mm, but other working distances may be available upon request.

The transmitter and receiver are securely mounted inside a sealed stainless steel housing. The lens is Teflon coated to resist solvents. All components in the hazardous area meet CID1 standards.

The SCS500n is ideal for industrial and pilot applications where the transceiver is to be deployed in an explosive environment (paint booth, chemical plant, etc.).

The “n” in the model number corresponds to the type of terahertz transmitter. n = 1 for a Type 1 transmitter and 2 for a Type 2 transmitter.

APPLICATIONS

- Industrial process control: commercial roofing; foam density; coating thickness; plastic extrusion; asphalt shingles
- Nondestructive materials inspection: aircraft; packaged goods; radome inspection; spacecraft; pipeline repairs
- Converting applications: paper coating; multilayer films; tire

KEY FEATURES

- Full transceiver functionality
- Collinear design
- Solvent resistant lens
- Safe in explosive environments
- Use to measure layer thickness
- Capable of being steam cleaned

BENEFITS

- No need for separate transmitter and receiver
- Simple orientation to target
- Use regardless of solvent
- Prevents costly explosions
- Saves money through process control
- Compact size minimizes potential collisions

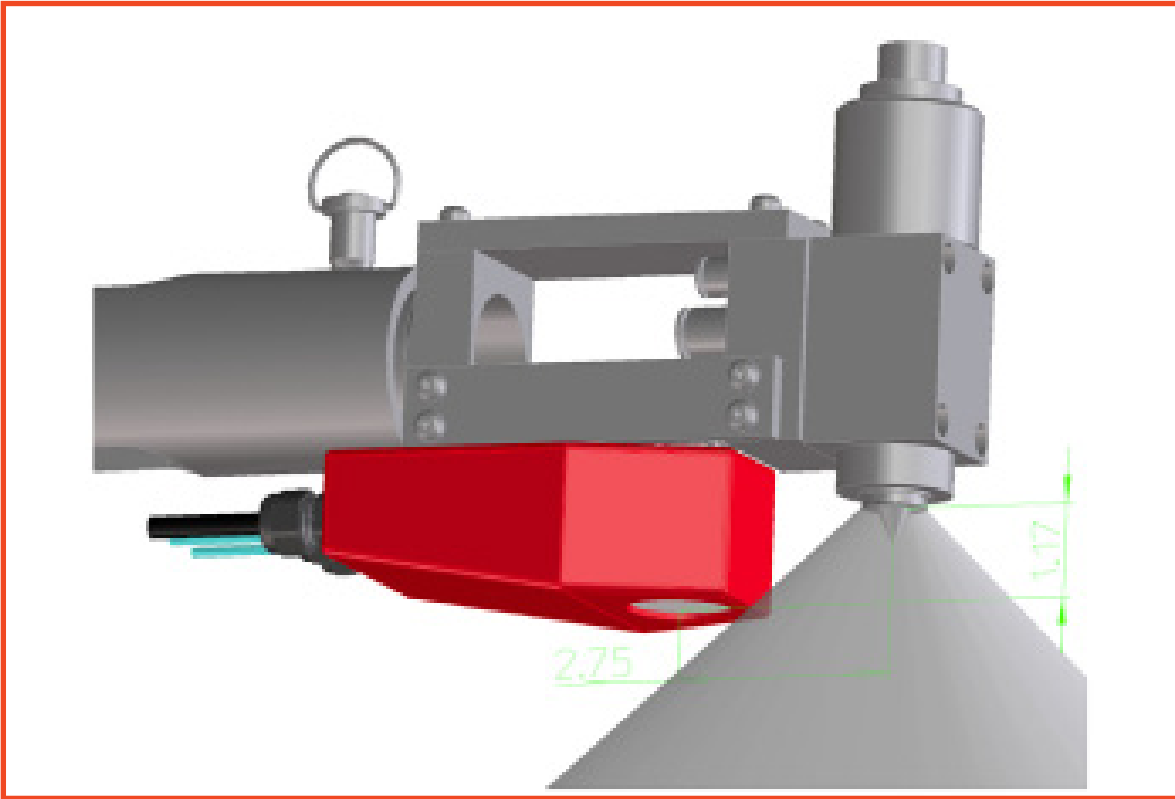

Example mounting configuration on paint spraying robot

ORDERING

Included

- Single Teflon coated 40 mm dia. HDPE lens (115 mm focal length)
- Single 10 m CID1 umbilical
- AJB5001 Junction Box
- Zener Barrier Junction Box
- 5m Zener Barrier Umbilical Extension

Typical Configuration

- Terahertz Controller
- T-Ray® Basic and T-Gauge® Software

Optional Equipment

- AJB5001 Junction Box
- 20m CID1 Umbilical Extension

Industry Leading Regulatory Compliance

The T-Ray 5000 intelligent TCU has been certified by Underwriters Laboratories has received the CE mark, is fully compliant with FDA CDRH laser safety regulations, and has been tested to meet FCC part 18 regulations.



2725 S. Industrial Highway, Suite 100
 Ann Arbor, MI 48104
 Phone: 734.926.4370
 Email: terahertzsales@lunainc.com