

REVISION HISTORY

REV	DESCRIPTION	DATE	EO NUMBER
A	Initial Release	10/9/2018	XXXXXXXXXX
B	Add sensor axis location	7/2/2019	XXXXXXXXXX

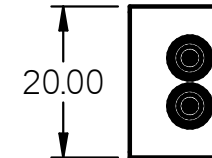
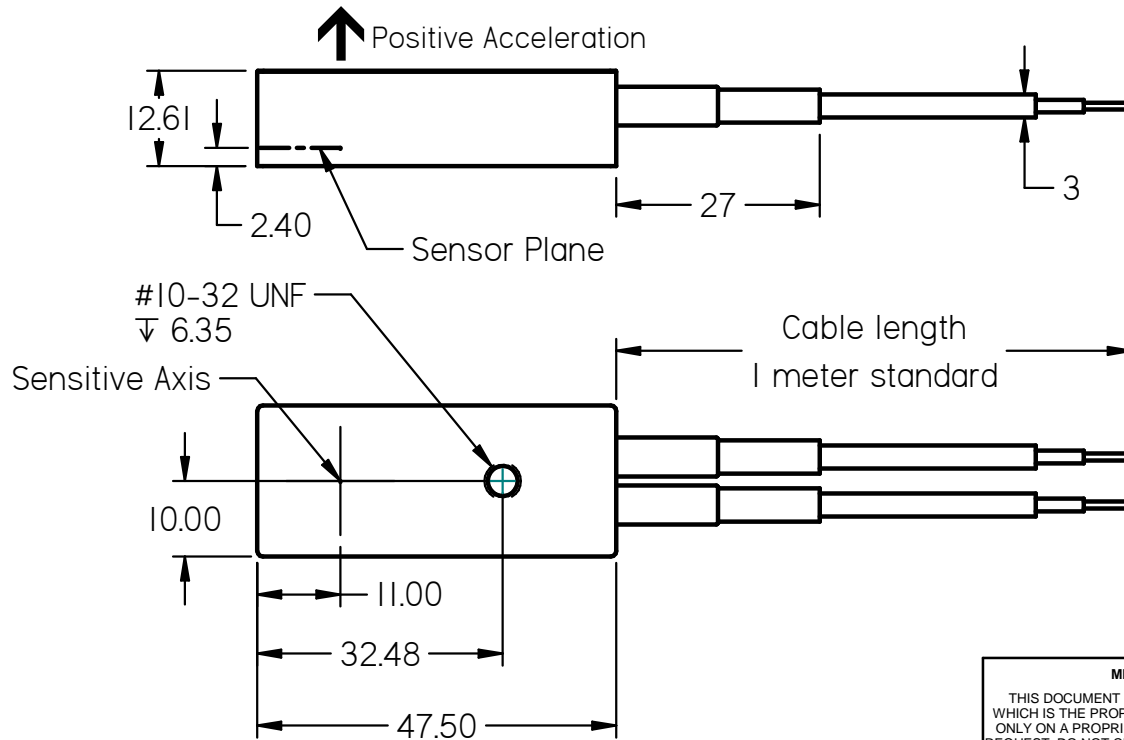
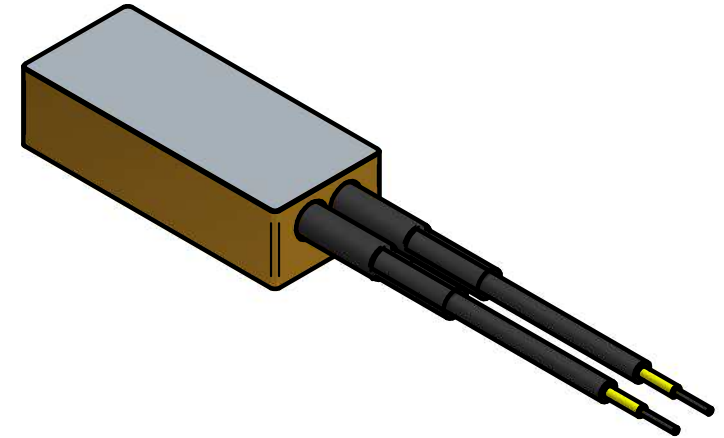
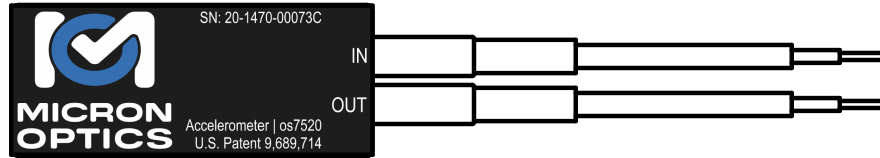

<p>MICRON OPTICS PROPRIETARY</p> <p>THIS DOCUMENT CONTAINS MATERIAL AND/OR INFORMATION WHICH IS THE PROPERTY OF MICRON OPTICS, INC. IT IS SUPPLIED ONLY ON A PROPRIETARY BASIS, AND MUST BE RETURNED UPON REQUEST. DO NOT CIRCULATE, REPRODUCE OR DIVULGE TO OTHER PARTIES WITHOUT WRITTEN CONSENT OF MICRON OPTICS, INC.</p>		<p>MICRON OPTICS</p>	
<p>DIMENSIONS IN MILLIMETERS</p> <p>INTERPRET DRAWINGS PER ANSI Y14.5 - 2009</p> <p>GENERAL TOLERANCE UNLESS OTHERWISE SPECIFIED</p> <p>DECIMAL MM X = +/- 1, X.X = +/- 0.5, X.XX = +/- 0.15</p> <p>ANGLES +/- 0.5°</p> <p>MACHINED SURFACES = 1.6um</p>		<p>Accelerometer os7520</p> <p>Customer Drawing</p>	
<p>PART NO</p>		<p>DRAWING NO</p> <p>740-400003</p>	
<p>DRN BY</p> <p>STEVE F.</p>		<p>SIZE</p> <p>A</p>	
		<p>SHEET 1 OF 1</p>	